

# TORNOS



*Benefit from a fivefold  
increase in productivity*

MultiSwiss range

# A revolutionary

## MultiSwiss

*A veritable revolution, the MultiSwiss is a line of products providing a link between multispindle and single-spindle turning machines. As simple to program and operate as a single-spindle turning machine, the MultiSwiss is 5 times more productive, enabling significant increases in production, both in terms of quality and uniformity. The MultiSwiss brings a new perspective to the production of intricate parts. The range is available in 3 diameters: 16 mm and 32 mm (6-spindle version) and 26 mm (8-spindle version). True machining centres, these machines can be equipped with a multitude of tools, ensuring they are capable of handling the most advanced operations.*

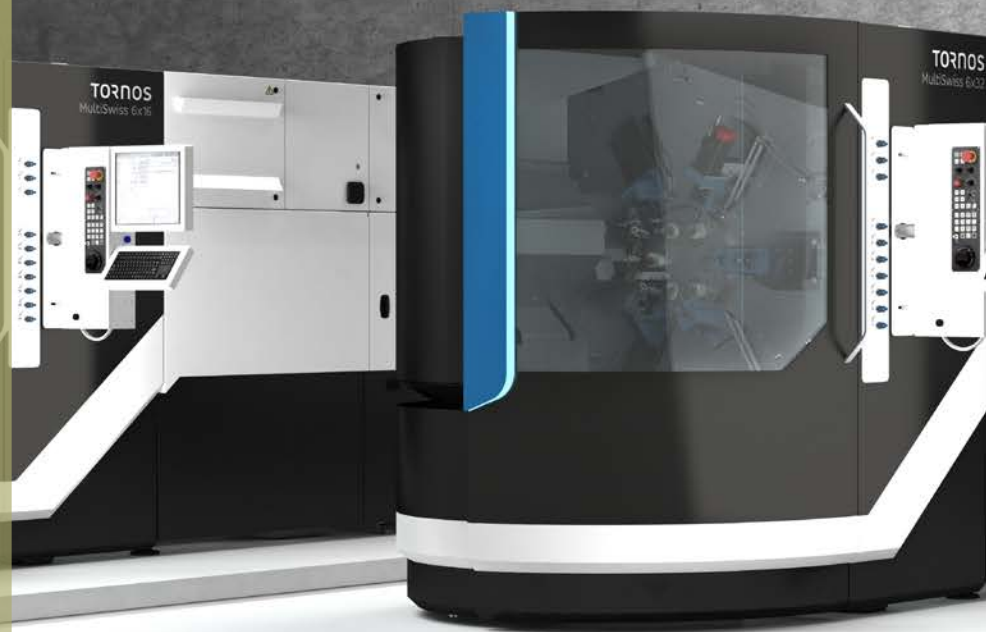

Number of C axes **7**

Up to tools **18**

**6** spindles

**16** mm  
maximum diameter

**MultiSwiss 6 x 16**

Number of C axes **8**

Up to tools **23**

# product range



6 spindles  
32 mm  
maximum diameter

**MultiSwiss 6 x 32**

9 Number of C axes  
8 spindles

Up to 31 tools  
26 mm  
maximum diameter

**MultiSwiss 8 x 26**

# A unique concept

## Unrivalled accessibility

The MultiSwiss is revolutionary. It is a new line of products that bridges the gap between single-spindle and multispindle machines. The MultiSwiss features 6 or 8 mobile spindles using torque motor technology to index its barrel. It is very fast and can deliver cycle times close to those of cam-operated multispindle turning machines. The many advantages offered by the MultiSwiss include

### Ergonomics

- Frontal access
- Easy to change setup
- Unrivalled accessibility
- Fully integrated peripherals

### Flexibility

- Independent speed and positioning for each station
- Plug & Run system for devices
- Y axes (optional)
- Pre-adjustable tool holders with integrated cooling
- Chucker (optional)

### Precision

- Precision, thanks to comprehensive machine thermoregulation
- All-in-one machine concept including the bar feeder, oil tray and filtration
- Ultra-fast barrel indexing thanks to the torque motor, and no locking time
- Reliable production of a wide variety of parts with strict tolerances
- Improved finish and unrivalled tool service life, thanks to the use of hydrostatic bearings

### Costs

- Reduced tooling costs
- Few interventions required, thanks to excellent swarf removal and management
- Extremely compact machine



# Ergonomics

*The MultiSwiss has been designed with the operator in mind: rather than having to bend over the machine, they can actually go inside it to change the tool holders. This front access is user-friendly, ergonomic, secure, innovative, and totally unique on the market: no other machine offers this level of freedom. Swarf removal is exemplary. As the slides are vertical, swarf falls directly into the conveyor.*

*Cooling is integrated within the slides, which reduces the use of pipes which can not only be difficult to adjust, but also easily trap swarf. This concept makes the MultiSwiss as simple to set up as a single-spindle turning machine, the only difference ultimately lies in the number of collets to change.*



# Quality machining and unrivalled productivity

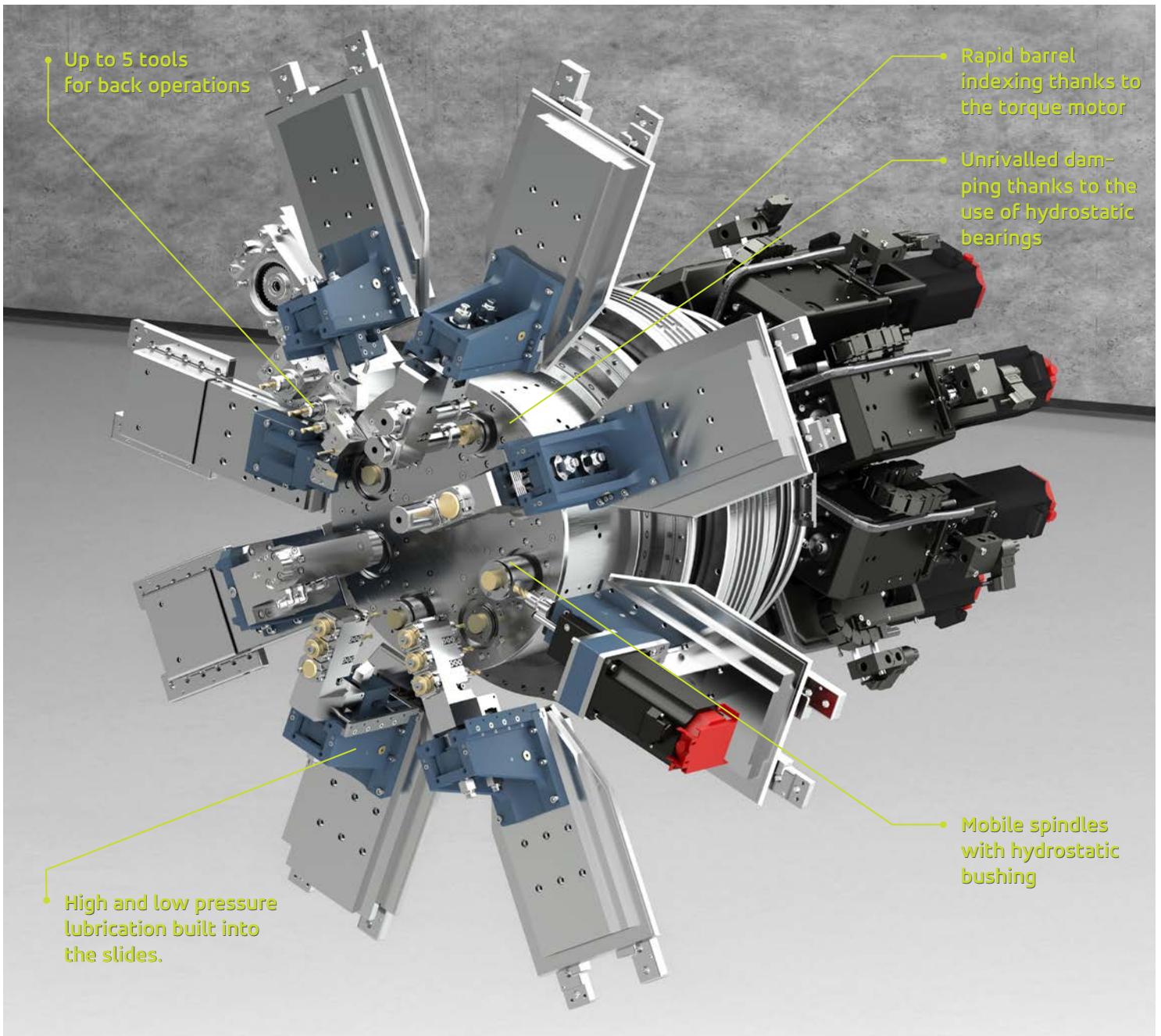

# Thermostabilisation +/- 0.5 degrees

## **Barrel indexing using torque motor technology**

*The barrel is the machine's heart, and great attention has been paid to its design and execution.*

*Compact, it can be equipped with 6 or 8 powered spindles with synchronous motors. Now more than ever, when using multispindle turning machines, productivity is key: each hundredth of a second counts. The barrel on MultiSwiss machines guarantees maximum precision in all positions.*

*Thanks to the indexing technology using torque motors, the MultiSwiss can achieve record indexing times of under 0.4 seconds, and does so with the lowest noise levels. As there is no Hirth gearing, the precious seconds normally spent locking and unlocking the barrel can be saved.*

## **High-performance spindles**

*Spindles with high-power synchronous motors ensure the machine offers impressive dynamics. The acceleration times are very short, and the torque provided is high. Each spindle is independent both in terms of speed and angular positioning. It is possible to ensure angular positioning between the spindles, and with the counter spindle.*

## **Optimal damping**

*Hydrostatic technology is one of the keys to the success of MultiSwiss machines. Each of the spindles is equipped with hydrostatic bearings. This technology increases damping during machining operations. The service life of tools can be extended by more than 30% in some cases. The additional damping this provides not only enables excellent machining finishes to be achieved, it also allows operators to tackle machining of hard materials with complete peace of mind.*

## **Total thermal management**

*The machine's precision is closely linked to its temperature response characteristics. Its temperature is fully controlled via the cutting oil which is monitored by a plate heat exchanger. The machine's core is kept at a constant temperature (+/- 0.5 degrees), even when stopped, to ensure normal operation during production. A dual heating/cooling tray is used, which enables the core temperature to be constantly fine-tuned and optimised. The MultiSwiss uses cutting oil to manage its hydrostatic technology, which eliminates any risk of contamination.*

# 30% reduction in tool wear

# Seamless integration

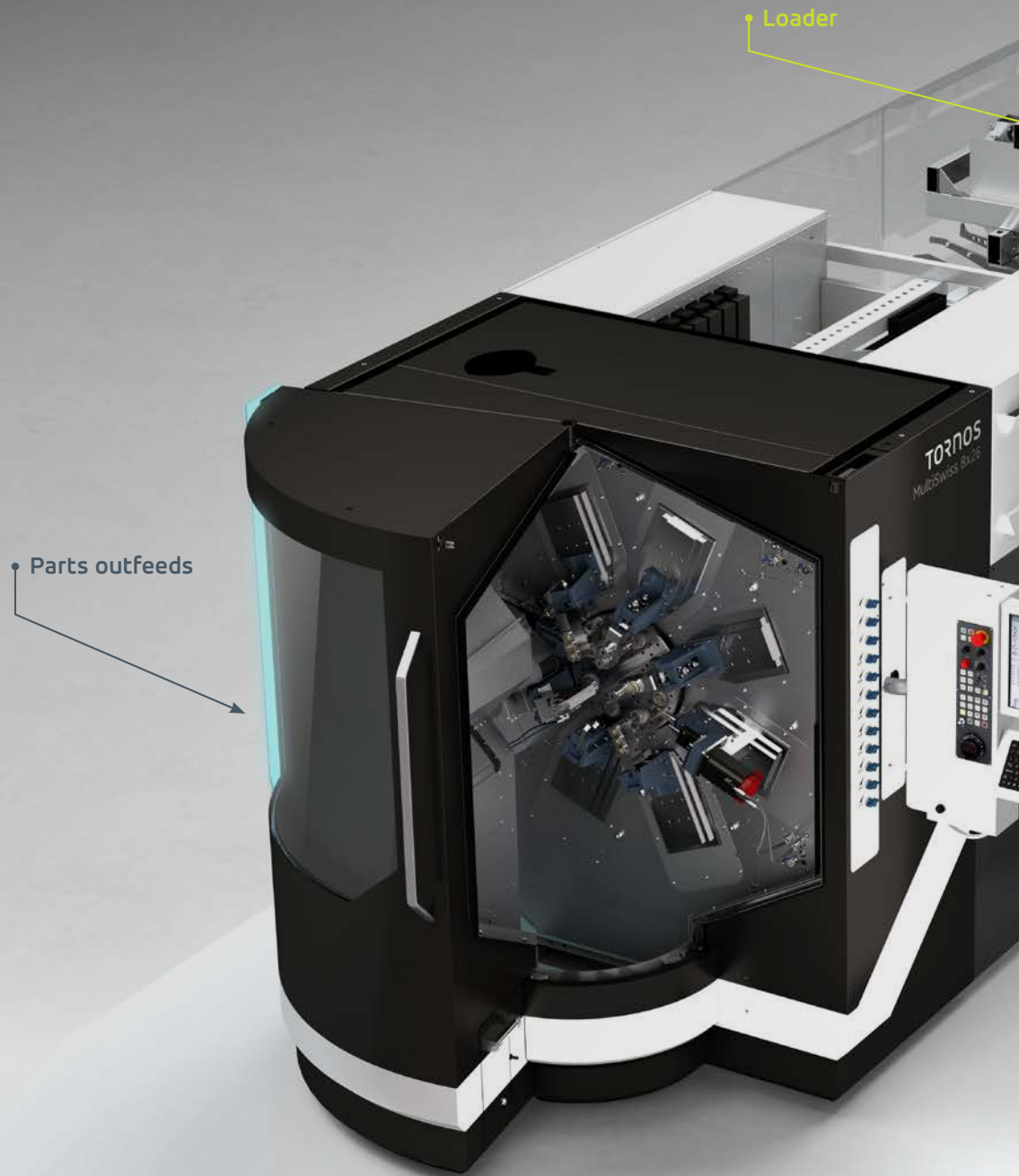

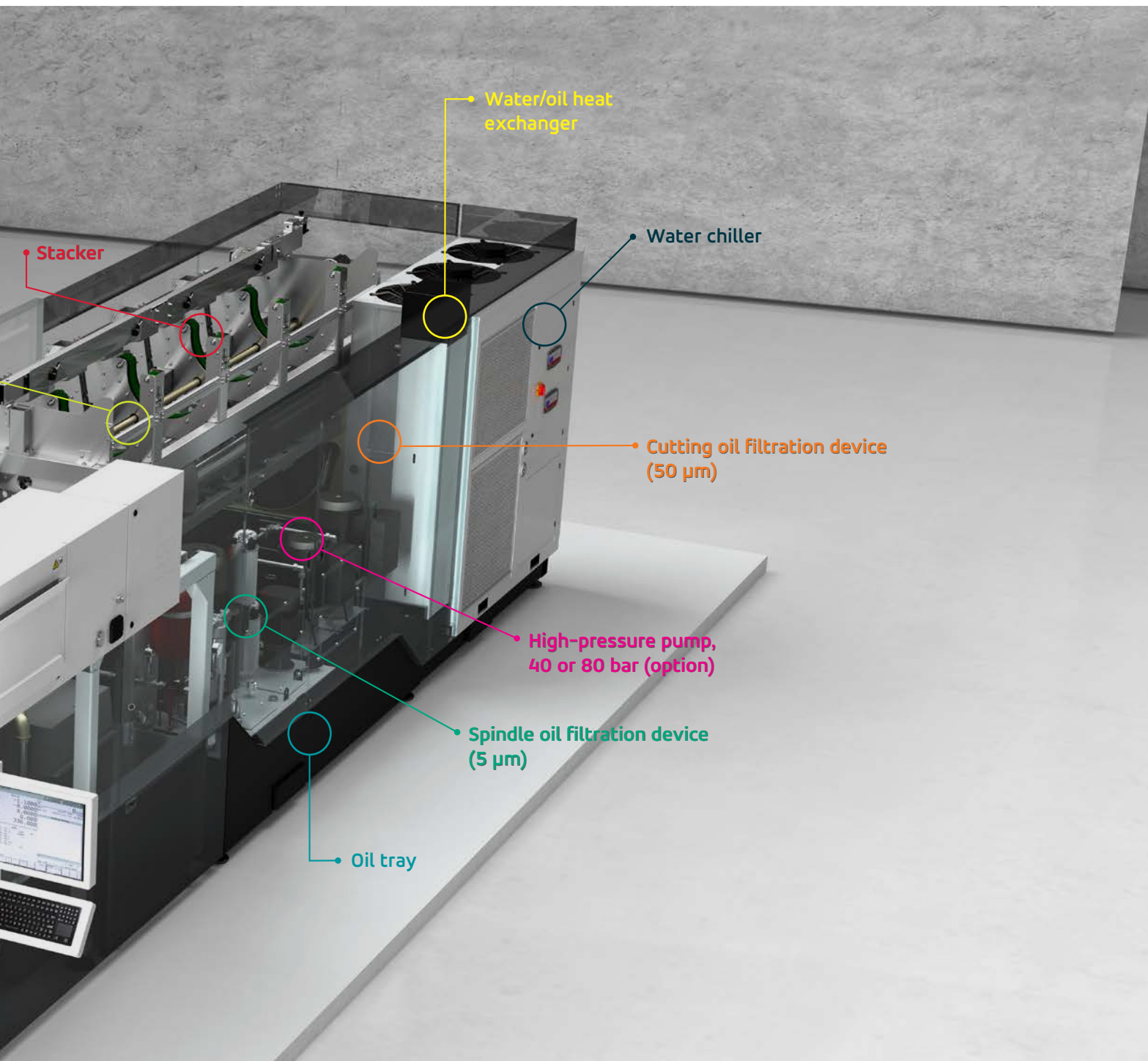

### An “all-in-one” concept

The MultiSwiss has a compact footprint: all the peripherals it needs to run effectively are housed behind the machine in a container. As standard, the MultiSwiss includes the bar feeder, the management system for swarf and oil with dual filtration incorporating a paper filter system (filtration to 50 µ) in addition to an ultra-fine filter (5 µ). Options such as the oil mist extractor, chip conveyor, fire protection system and high-pressure coolant pump are integrated seamlessly into the machine. The fact that this integration has been incorporated from the design stage means that

the machine footprint is reduced, and the MultiSwiss can quickly find its place in the heart of any workshop. The machine is extremely compact thanks to the smart design of its peripherals. This allows the MultiSwiss machine to be installed in place of either a single-spindle machine with its bar feeder or a cam-type machine with a similar capacity.

MultiSwiss 8x26 and MultiSwiss 6x32 machines can be equipped with an optional stacker to further increase autonomy for parts with a short cycle time.

# Seamless integration



## **Automated parts outfeeds**

*The parts outfeed can also be adapted to your requirements, as the MultiSwiss range offers a vast choice of solutions enabling parts to be efficiently extracted from the machine. Standard parts outfeeds can be completed by a conveyor belt or carousel system, enabling the production run to be split. These devices can also be supplemented by a vacuum system (venturi) for effective handling of the outfeed of small parts.*

*The carousel systems can be adapted based on the required autonomy and the type of parts being manufactured. It is possible to select the small internal device or several types of external carousel. Once the programmed quantity of parts has been reached, the position of the carousel will be indexed and the parts will be deposited in the next tray. The day's production is therefore split into several batches. This device can also be used*

*for production configured for parts in the same family, so that the part can be changed automatically (multi-program functionality).*

## **Palletising**

*A controlled, programmable parts unloading system is available to meet growing demand for the ability to produce impeccable parts completely free from any blemish.*

*The offering includes different systems, enabling your requirements to be met precisely, for example:*

- *A Cartesian system which unloads each part individually, placing them outside of the work area.*
- *A robot which transports the part from the work zone onto pallets, providing the perfect conditions for maximum flexibility, and allow-*

ing other operations such as pre-cleaning, measurements and the selection of parts to be performed.

Numerous leading-edge companies have automated their processes, due largely to the cost of labour and because of the extremely high quality they require. Do not hesitate to contact our team of specialists who will be able to advise you on a custom solution perfect for your needs.

### Chucker

Depending on market requirements, a chuck clamping or "Chucker" process may be necessary. There is also a range of loading options, based on specific requirements (using gravity, linear axis or 5-axis robot). Thanks to its open kinematics, which leaves plenty of space for the loading device, the MultiSwiss is the perfect platform for this type of application. As it boasts a mobile spindle, the machine no longer needs to be equipped with micrometer stops as the Z axis uses the numerical control to monitor this gap between the spindles. No other machine on the market offers this feature. Furthermore, the MultiSwiss can be easily converted from a chucker machine to a bar machine as required.

### Recovery of bar remnants

All MultiSwiss machines have front access for remnant extraction. This concept is one of the cornerstones of the machine's productivity: it allows a bar to be loaded in less than 10 seconds, which is three times faster than a conventional integrated bar feeder.

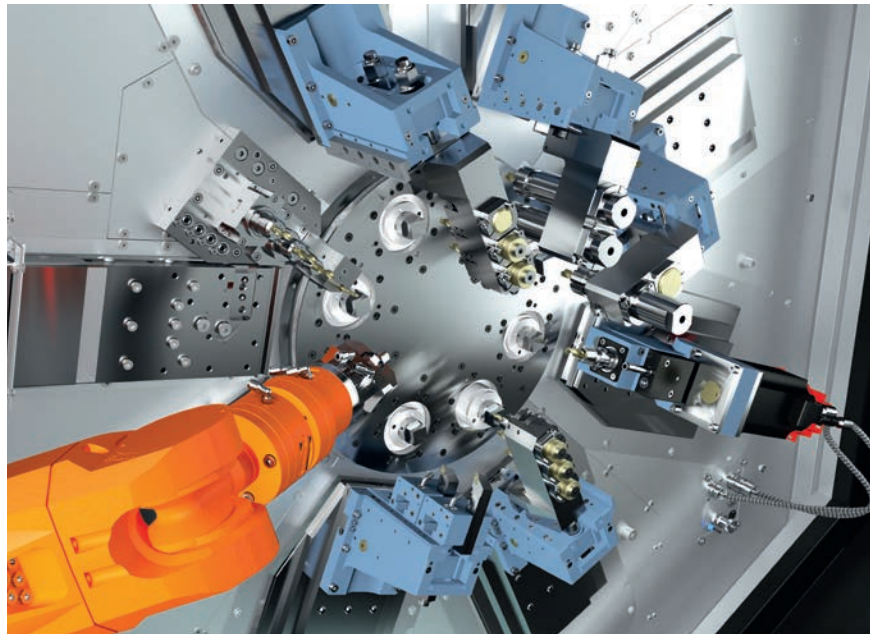

♻️ Programmable carousel for sorting parts

# Lightning-fast setups

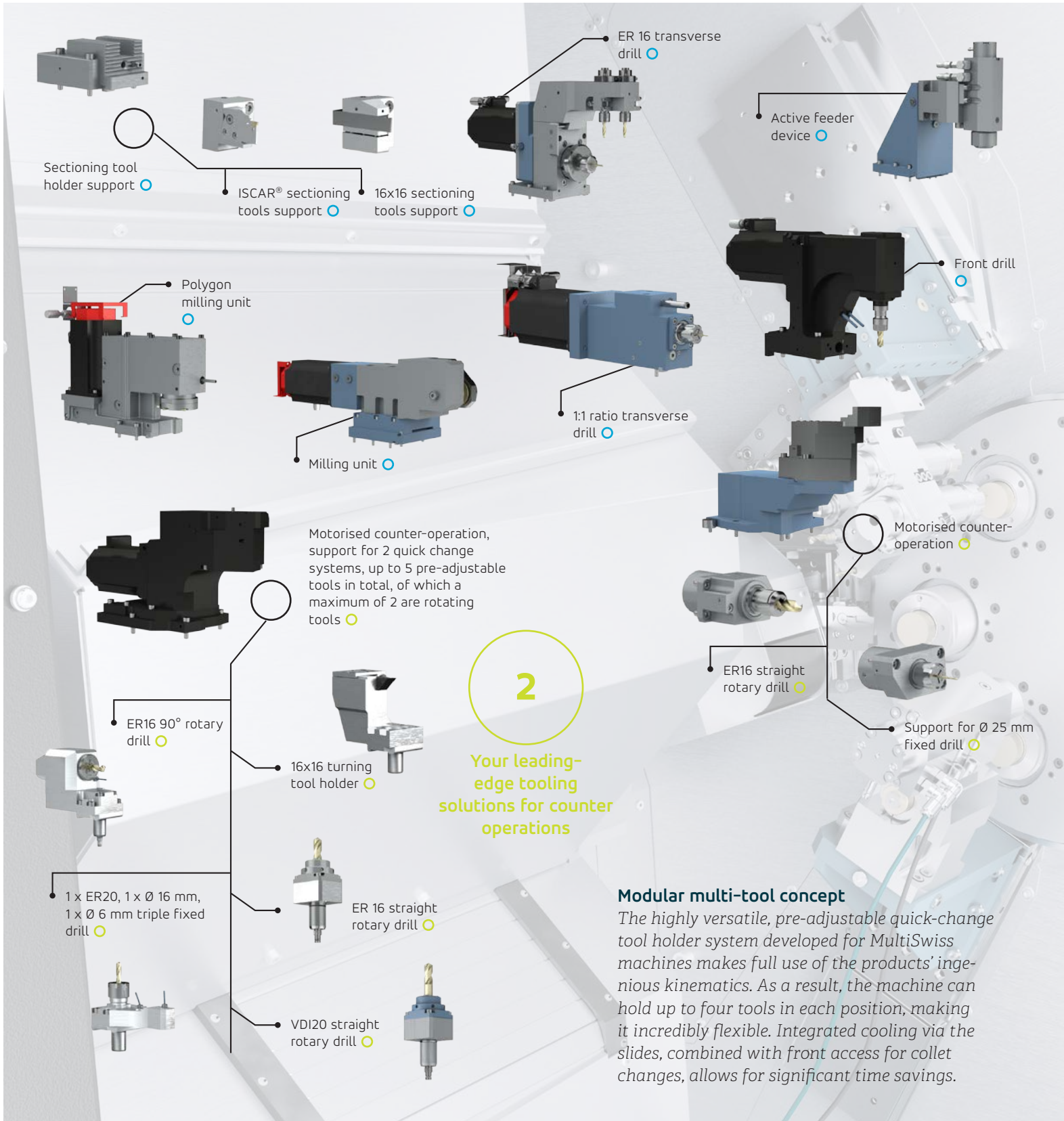

1

**Your leading-edge tooling solutions for main operations**



Basic support

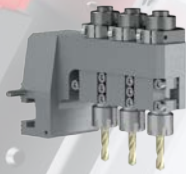

Support for 3 x Ø 25 front units



16x16 turning tool holder



Support for 2 x Ø 36 front units



2:1 ratio front drill



Polygon turning unit



Transverse drill



Basic support + Intermediate support



Tool holder for 2 x Ø 30 mm fixed drill

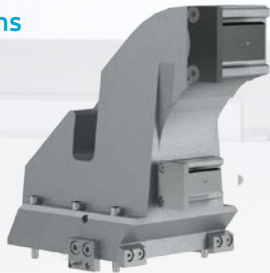

Base holder, includes 1 position for turning toolholder and 1 position for front operations



16x16 turning tool holder



Tool holder for 2 x Ø 30 mm fixed drill



Sectioning tool holder



ISCAR® sectioning tools support

**A plug & play system which completes the machine's ergonomics**

All machines in the range are designed to be equipped with any of a number of devices, for example: polygon operation units, standard drills or even thread-whirling devices. The rotating tools have an integrated motor which can be controlled directly by the numerical control, enabling the speed to be adjusted during machining. The plug & play system also includes management of high-frequency spindles in main and back operations, as required.

The management of tool holders and devices, coupled with excellent access to the machining area, allows setups to be performed as quickly as on a single-spindle turning machine. The machine is simple to use by any type of operator with knowledge of NC machining.

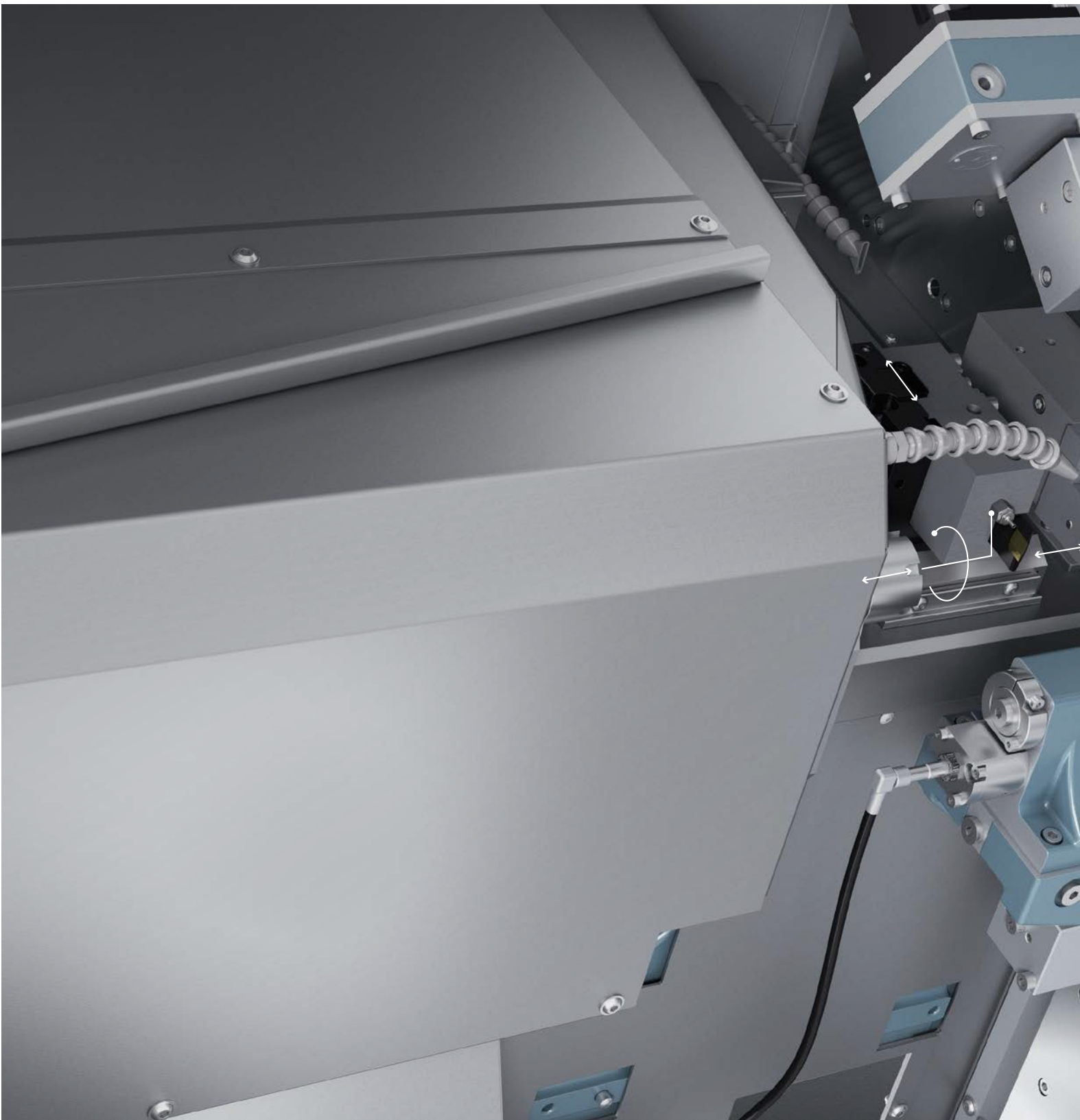

*MultiSwiss 6 x 16, the MultiSwiss range trailblazer. Quick, flexible, and accurate, it has become an industry benchmark.*

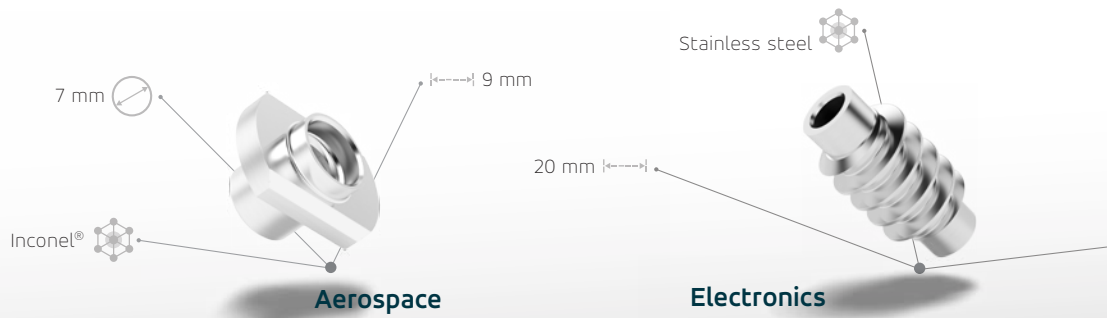

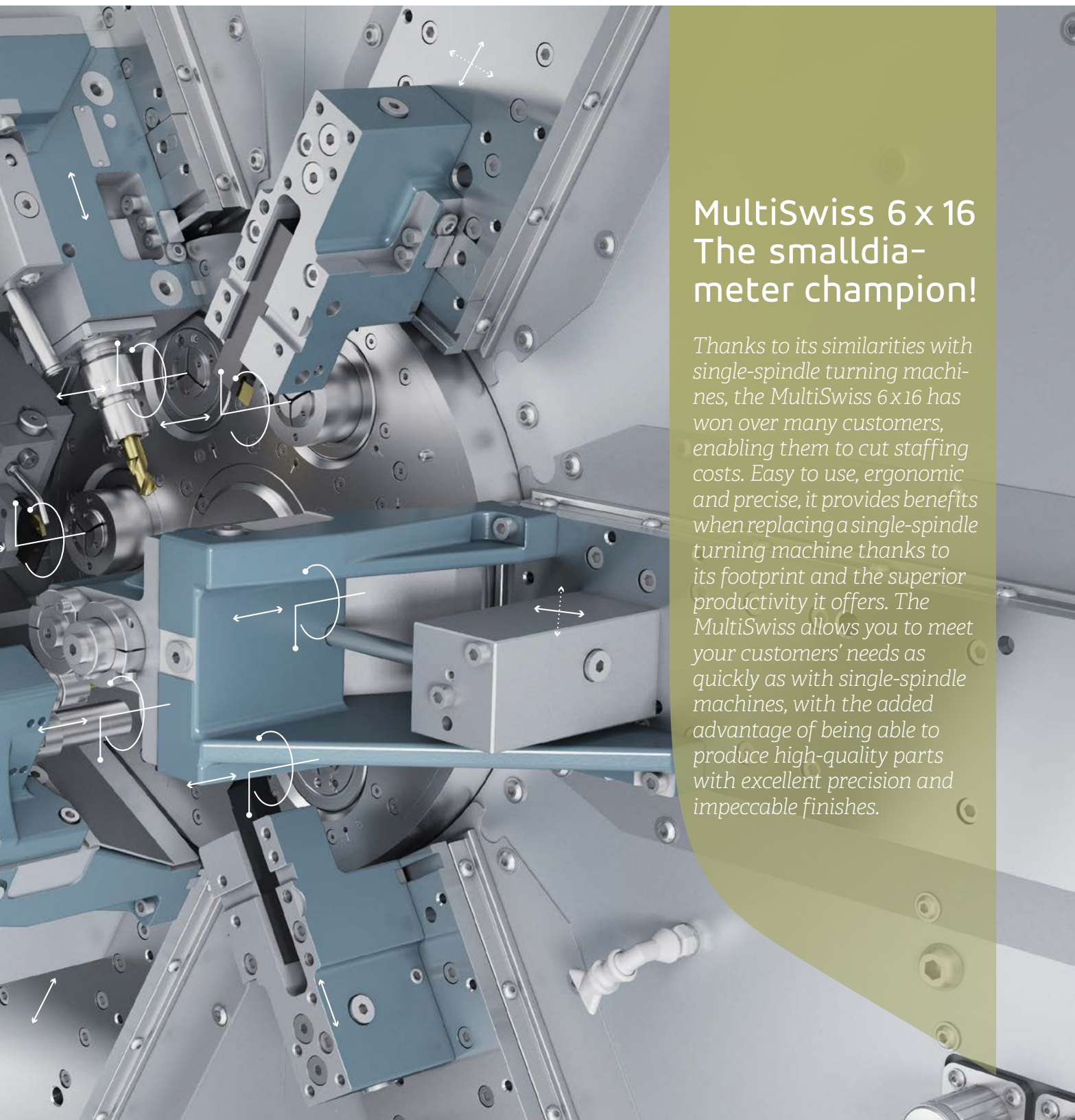

## MultiSwiss 6 x 16 The small diameter champion!

*Thanks to its similarities with single-spindle turning machines, the MultiSwiss 6x16 has won over many customers, enabling them to cut staffing costs. Easy to use, ergonomic and precise, it provides benefits when replacing a single-spindle turning machine thanks to its footprint and the superior productivity it offers. The MultiSwiss allows you to meet your customers' needs as quickly as with single-spindle machines, with the added advantage of being able to produce high-quality parts with excellent precision and impeccable finishes.*



## MultiSwiss 8 x 26 Eight spindles for even more options

Thanks to its eight stations, the MultiSwiss 8x26 is able to perform complex operations. Each of the 8 stations can house 4 tools. For more straightforward parts, the increased number of stations allows roughing operations to be performed, thereby increasing efficiency. The counter spindle is mounted on two axes which means it can work completely independently with 4 tools, 2 of which can be rotating. The machine is available in three configurations: entry-level with no Y axis, intermediate with 3 Y axes, and complete with 6 Y axes for the most complex parts.

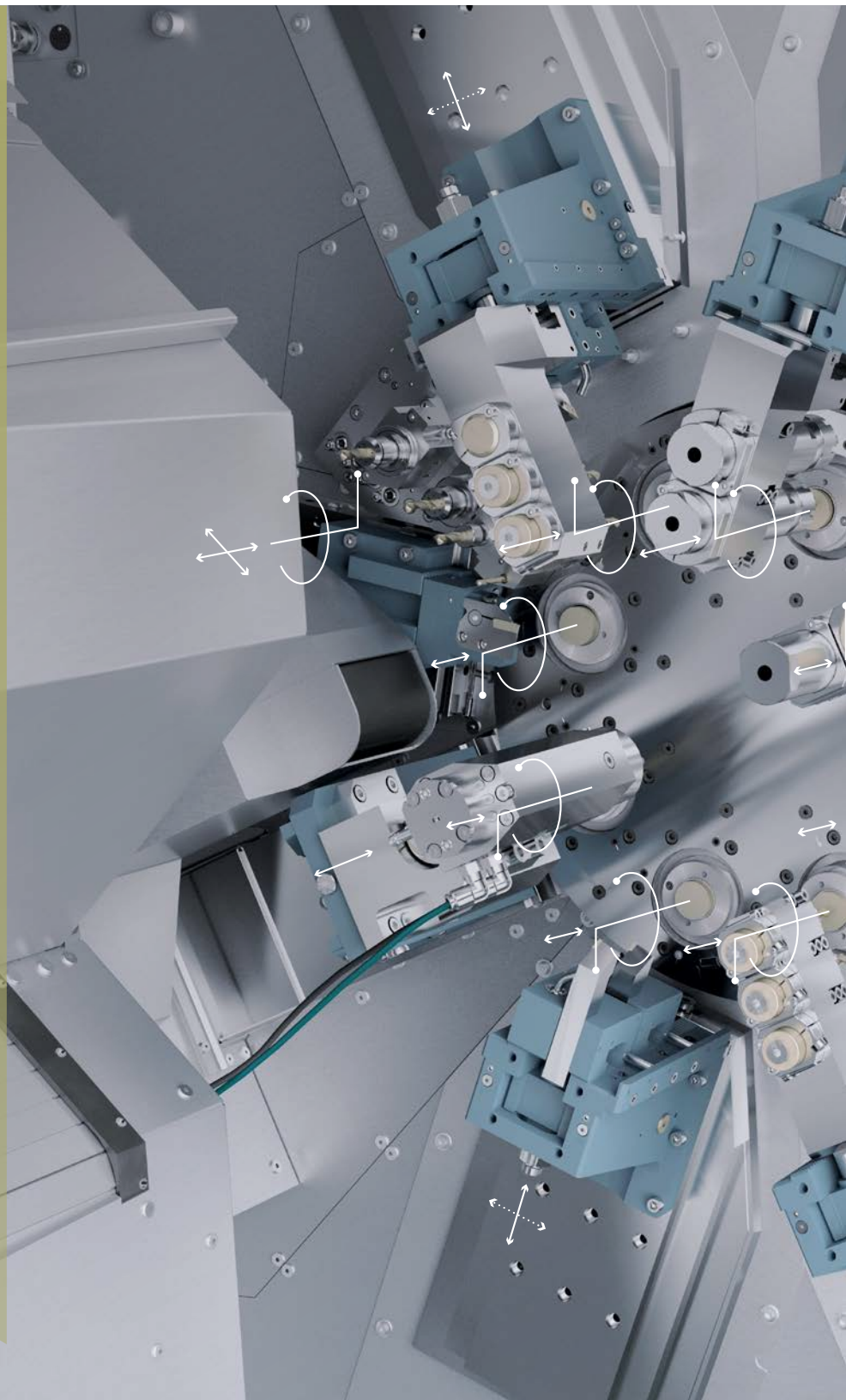

Increase your productivity, whatever your machining challenges.

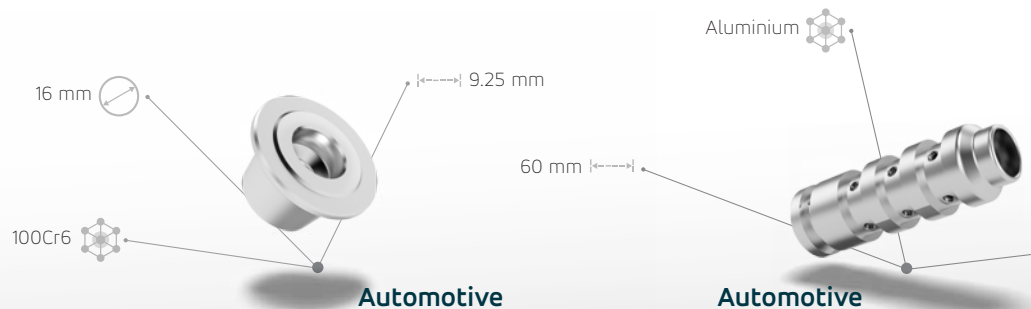

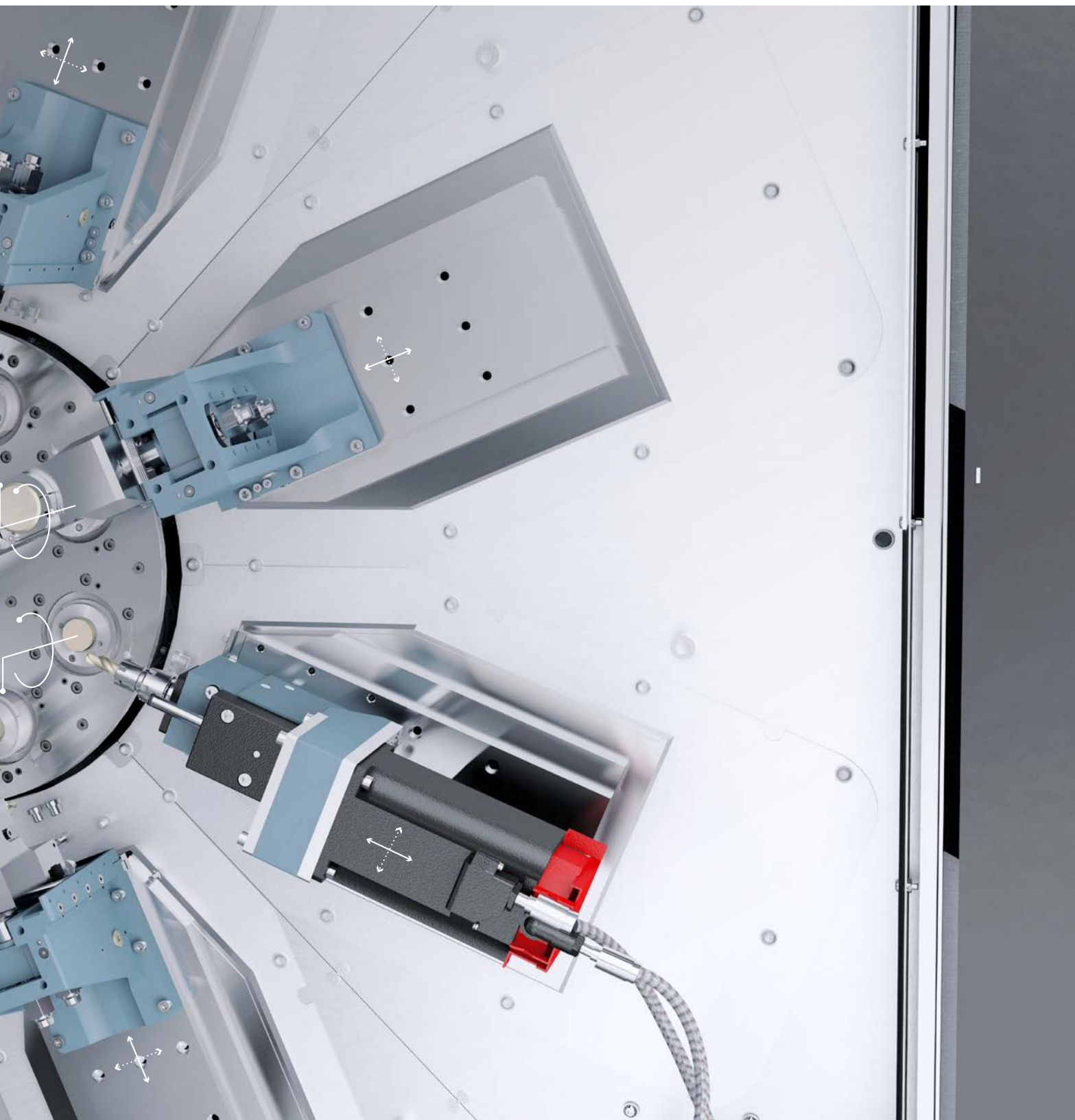

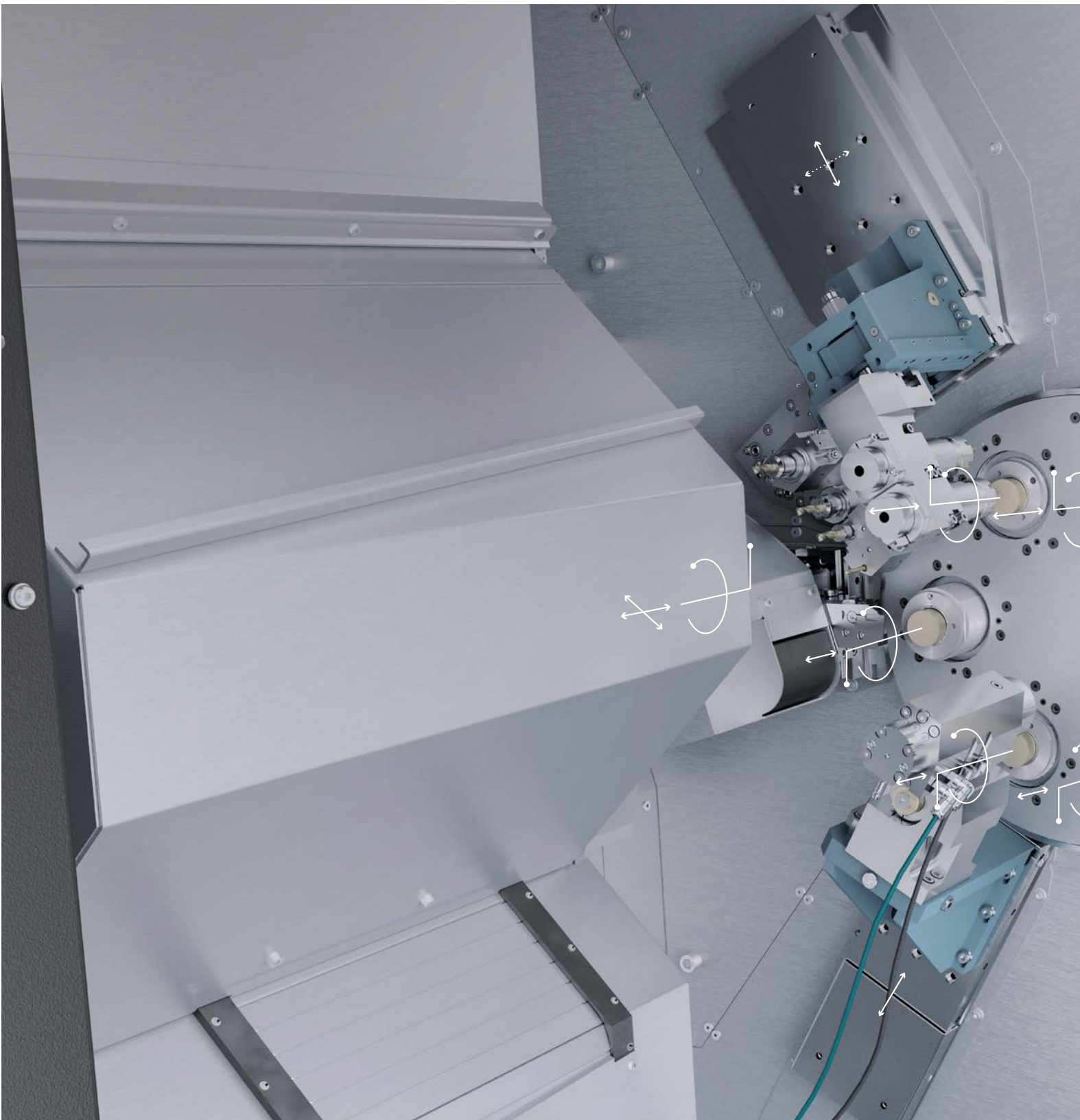

*A vast range of applications at your fingertips.*

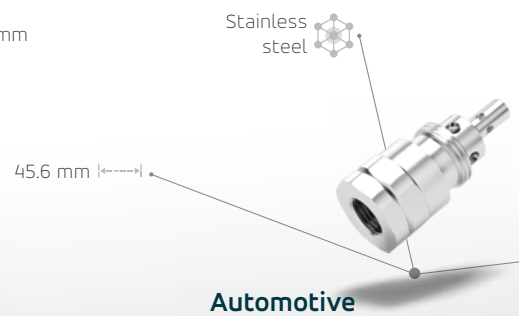
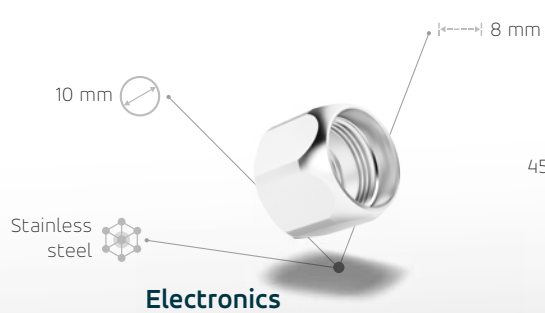

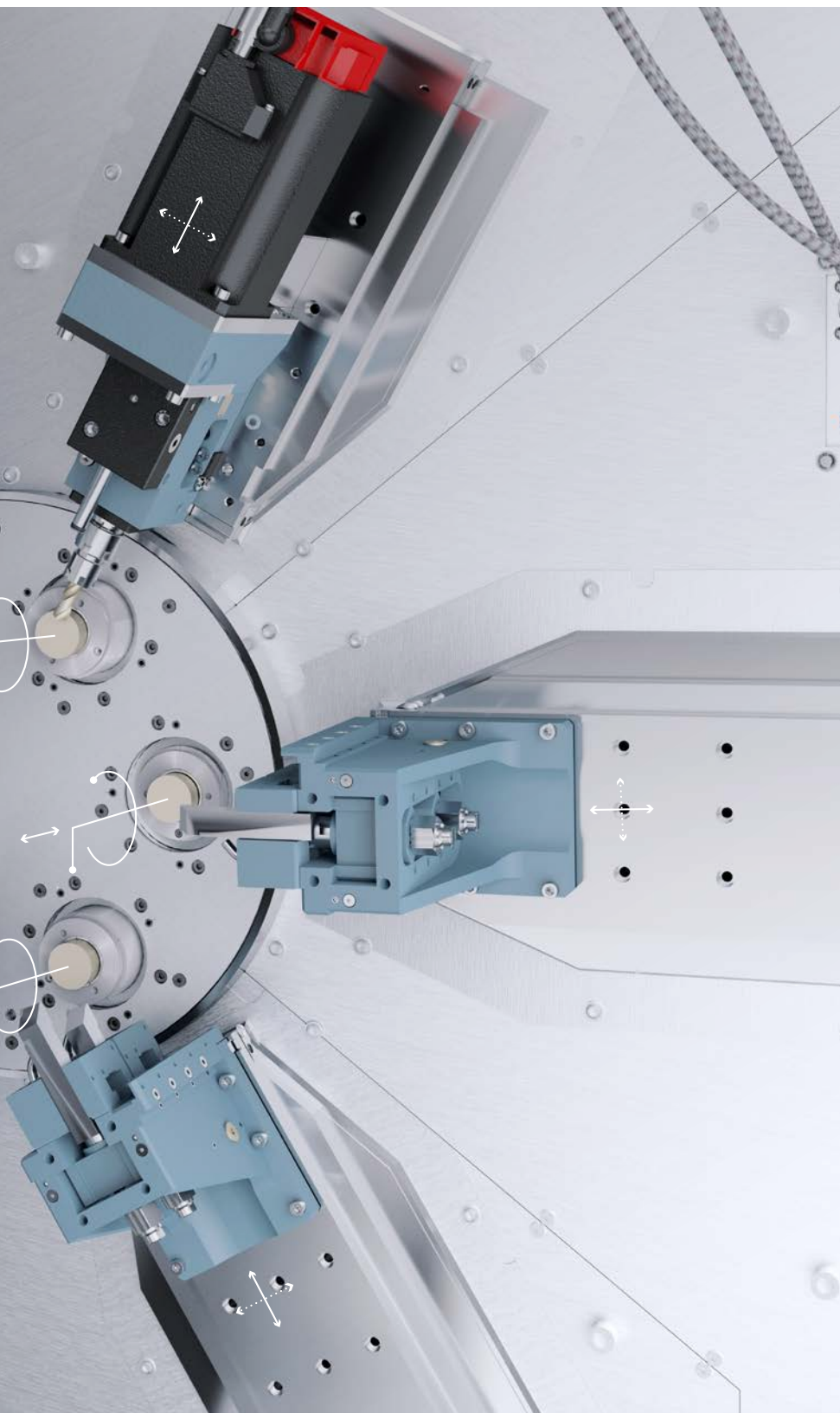

## MultiSwiss 6 x 32 - 32 mm, 27 Nm, perfect for large diameters

*The MultiSwiss 6 x 32 shares the same base as the MultiSwiss 8 x 26 machine. As an option, the machine can also be equipped with three Y axes. Just as with the MultiSwiss 8 x 26, up to 4 tool positions, 2 of which can be driven, are available for back operations, allowing complex operations to be performed.*

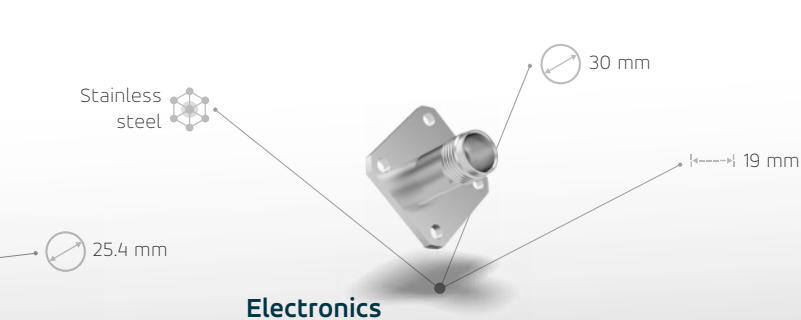



Connectivity pack  
Option

ios

Android

Mobile  
app

App TISIS tab

Monitoring  
TISIS screen & TISIS tab

TISIS Vision Setup  
Option

TISIS ii4.0  
Option

TISIS CAM  
Option

3D simulation  
of operations

Complex  
operation

TISIS  
Lite

Programming

TISIS

Programming

Virtual tool  
setup

Compare  
parts

Storing  
datas

# TISIS and TB-DECO: Programming and communicating with your Multi- Swiss machine

## Experience programming intelligence

In today's competitive global marketplace, there's not a moment to waste in meeting customers' demands. Our available TISIS communication and our TB-DECO programming software put you on the fast track to truly effortless programming and real-time process monitoring. But that's not all: TB-DECO enables you to assess each machine's options, reduces the risk of collisions and the resulting downtimes, and improves your production efficiency. TB-DECO is a programming assistance system which generates tables to control the paths of each axis and spindle, firmly based on the operation of a cam-type machine. To enable this, it is equipped with a powerful computer with an integrated interpolator and a machine simulator. The software enables the operator to visually position the operations on a timeline, and to generate a more efficient code for the CNC. It works in the same way as the editing software used by amateur filmmakers, and makes it very easy to position operations in the desired location. Since tools already exist in their database with geometric details, the desired movements just need to be indicated using the ISO code.

## Industry 4.0

At the same time, TISIS takes the complexity out of process monitoring, enabling you to take your first steps into the Industry 4.0 universe. Even from a remote location, you can keep an eye on the details of the machining process from your smartphone or tablet. The software also enables you to quickly transfer your programs, either by USB key or directly onto the machine via your company network. Your parts designs in various stages of completion can be stored with your program. These can then be easily found in the database using a search function.



Discover the  
TISIS video

# Tornos Service

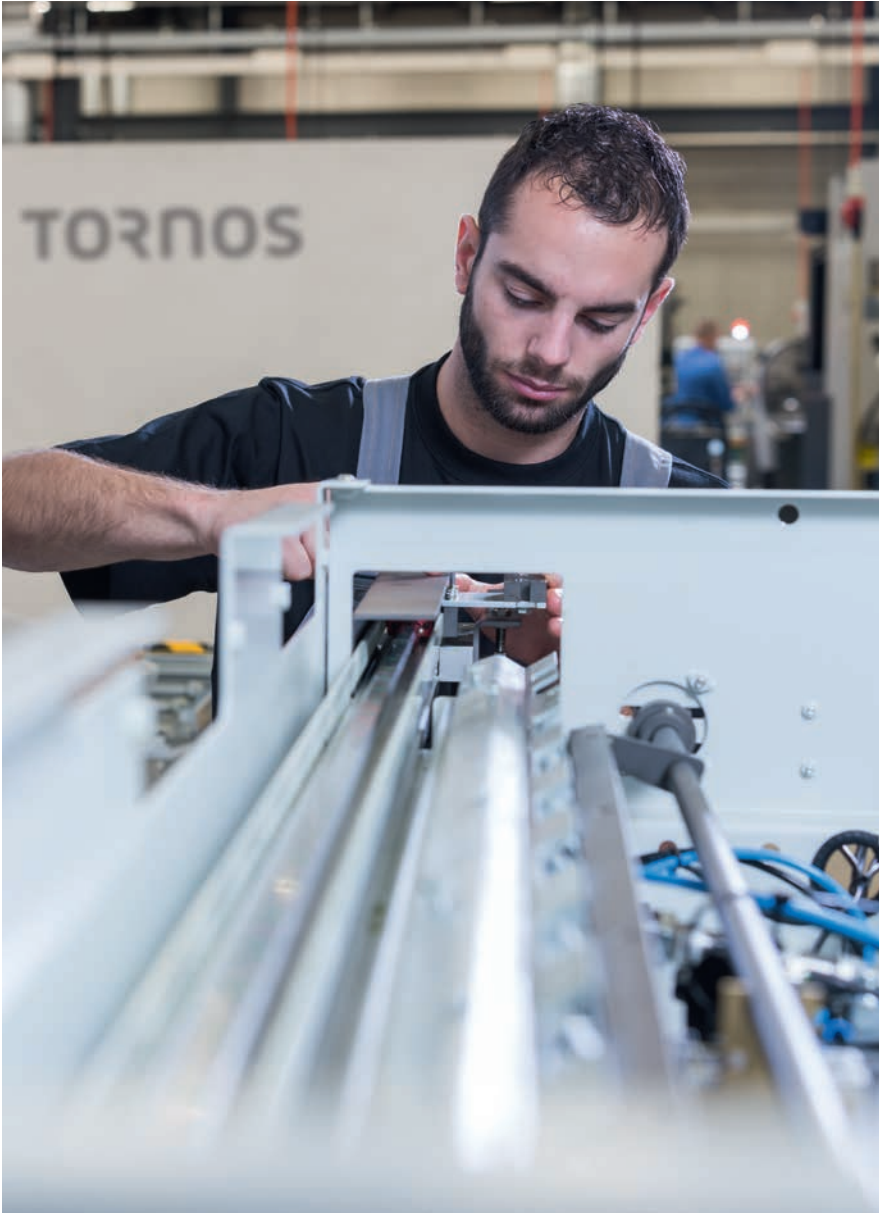

Backed by both geographical proximity to customers and an in-depth understanding of their processes, applications and market challenges, Tornos Service delivers an unparalleled continuum of support: start-up assistance, expert training and coaching, free hotline, on-site operations support and preventive maintenance, original spare parts seamlessly delivered worldwide, complete overhauls to extend the service life of Tornos machines, and a range of operations and X-change modules to expand customers' application capabilities and profitability.

Buying a Tornos machine is much more than a business transaction. It is your investment in the future. Tornos Service thrives worldwide by guaranteeing the superior production capabilities of products carrying the Tornos name.

Situated close to its customers, as demonstrated by the 12 Tornos Service Centres strategically located across Europe, Asia, and the Americas, Tornos Service offers a comprehensive range of leading support services for Tornos machines, and encompasses the innovation, reliability and attention to detail expected of a premier Swiss brand. And it is all backed by a 100-year legacy of expertise and in-depth understanding of customers' processes, applications and challenges across a wide range of industrial segments, including automotive, medical, electronics and connectivity, and micromechanics.

## **Start-up assistance**

From the first feasibility tests prior to purchase, you are in good hands with Tornos Service. In our state-of-the-art Techno Centres, expert application engineers support you with tests to gauge the feasibility of machining processes and applications. With start-up assistance, you are secure in the knowledge that you will never be left alone to deal with a brand new machine.

## **Expert training and coaching**

Engineered for intuitive and easy use, Tornos machines offer a vast range of options and enable myriad processes. Expert training and coaching help your employees become specialists proficient in programming, handling and maintenance, adding more value to your processes, applications and products.

## **Free Hotline support**

Wherever you are in the world, highly qualified specialists who speak your language and understand your processes are just a phone call away to quickly support you with handling and programming solutions.

## **On-site support**

Fast, efficient on-site operations and preventive maintenance ensure the continuous high performance of your Tornos machines. Regular sched-

uled preventive maintenance can help you avoid 70% of machine breakdowns and keep you on the path to productivity.

### Certified original spare parts

Rapid, reliable, worldwide delivery of certified original spare parts is a speciality of Tornos Service. Regardless of the age of your Tornos machine, we stock the essential certified spare parts to keep the machine running at peak performance.

### Machine overhauls

Tornos machines inspire confidence. It's no surprise, therefore, that many customers turn to Tornos for a complete overhaul of their machines. The Tornos overhaul service returns the machines in good-as-new condition, significantly extending their service life.

### Options, upgrades and X-change modules

To help you achieve your manufacturing, productivity and quality objectives, our experts collaborate with you to manage complex machining processes, develop software features for machining complex shapes, design special equipment, and tailor peripherals to your needs. Tornos' X-change modules expand your application capabilities and profitability.

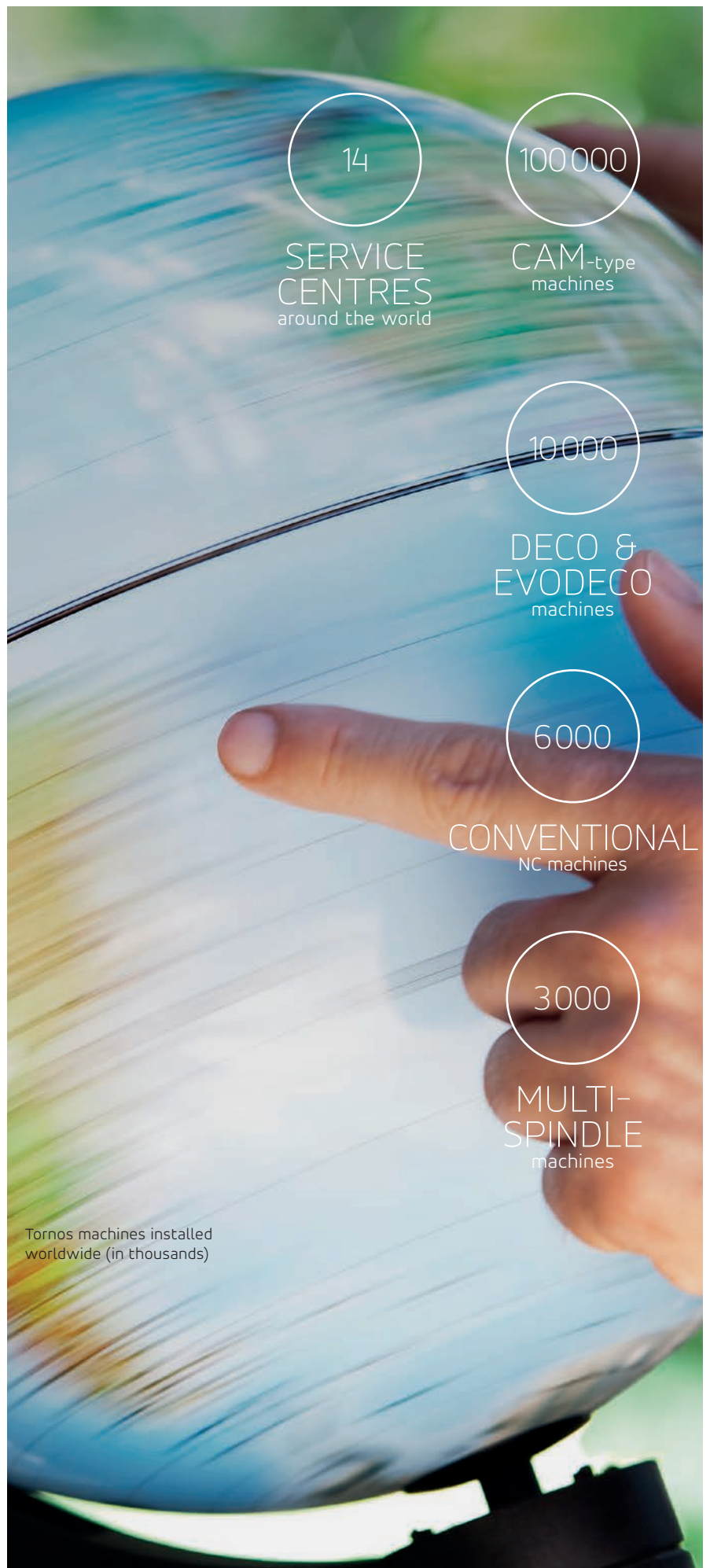

Discover  
Tornos Service

# Technical specifications



## TECHNICAL SPECIFICATIONS

Bar capacity		mm
Max. part length		mm
Max. remnant length		mm
Barrel indexing time		sec.
Max. spindle speed		rpm
Spindle output		kW
Spindle torque		Nm
Counter spindle max. speed		rpm
Counter spindle motor output		kW
Counter spindle motor torque		Nm
Spindle Z stroke		mm
Counter spindle Z stroke		mm
Number of linear axes		
Number of Y axes		
Number of rotating axes (C axis)		
Number of cross slides for main operation		
X stroke of cross slides for main operation		mm
X stroke of cross slides for main operation with Y axis		
Y stroke of the transverse slide for main operation		mm
X stroke of cross slides for back operation		mm
Z stroke of cross slides for back operation		mm
Max. number of tools		
Max. number of tools for back operation		
Max. number of rotating tools for back operation		
Spindle cooling		
Cutting oil filtration		µm
Oil tank capacity		l
Standard cutting oil pump:	outlet pressure	bar
	flow rate	l/min
High-pressure pump (options):	a) outlet pressure	bar
	flow rate	l/min
	b) outlet pressure	bar
	flow rate	l/min
Max. length		mm
Max. width		mm
Max. height		mm
Weight		kg
Installed power		kW
Numerical control		
Programming system		

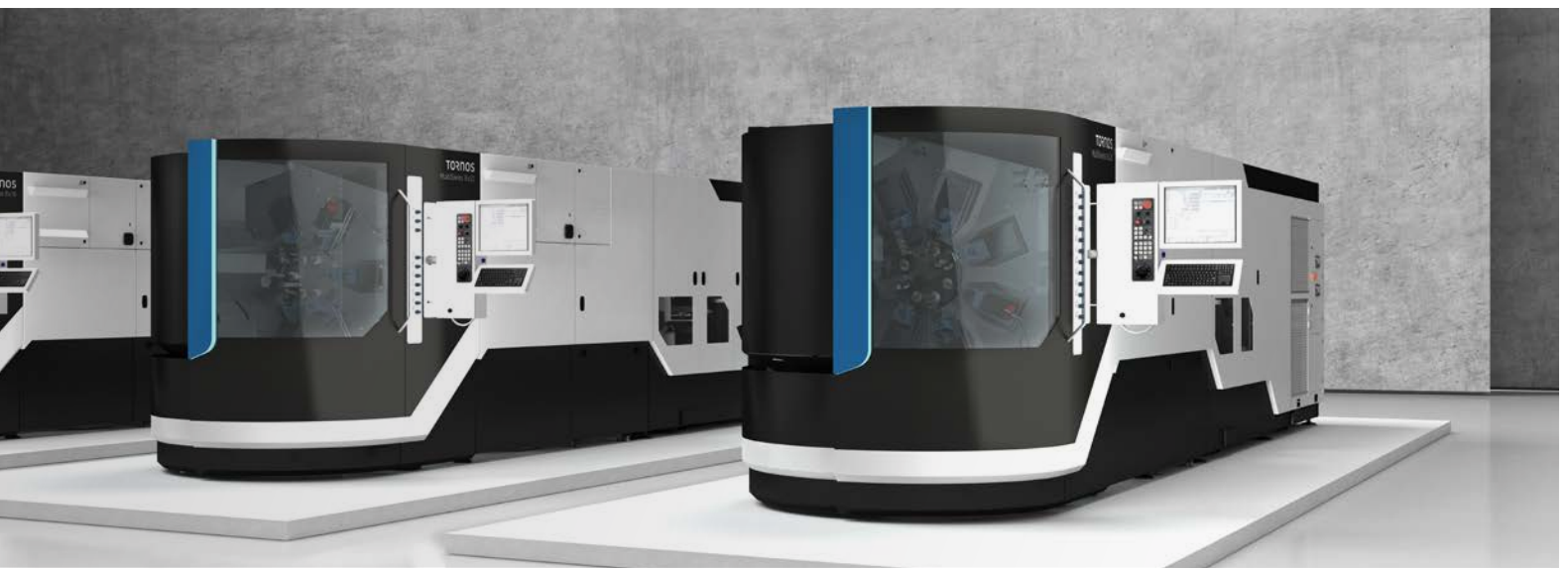

### MultiSwiss 6 x 16

### MultiSwiss 8 x 26

### MultiSwiss 6 x 32

4-16	8-26	8-32
40	65	65
70	140	140
0.40	0.48	0.50
8000	8000	6000
5.60	11.00	11.00
7.5/10.2	17/24	20/27.5
8000	8000	8000
5.00	11.00	11.00
8.00/10.00	12.0/15.5	12.0/15.5
50	75	75
150	150	150
14	18	14
1 (option)	3/6 (option)	3 (option)
6+1 (option)	8+1	8+1
5+1 (cutting)	7+1 (cutting)	5+1 (cutting)
40	80	80
	55	55
30	33	33
75	170	170
150	150	150
18	31	23
2	4	4
1	2	2
Oil	Oil	Oil
50	50	50
900	2000	2000
4.30	4.50	4.50
100	140	140
40	40	40
37	37	37
80	80	80
36	36	36
5920	9000	9000
1440	2260	2260
2120	2160	2160
7000	15,000	14,800
59	140	140
Fanuc	Fanuc	Fanuc
TB-DECO ADV	TB-DECO ADV	TB-DECO ADV

# A global footprint

*Rooted in Switzerland, Tornos' global footprint keeps us close to you. Economy, flexibility and efficiency are the most important premises of the Tornos Group's production and assembly network.*

*Lean assembly and careful use of resources are the guiding principles behind all Tornos production planning and an integral part of the entire production process.*

*The same consistent quality standards are enforced at all locations around the globe. Intelligent linking of knowledge between our plants, along the commitment and know-how of our employees—enable production to begin right on time.*

*Wherever you are in the world, we keep you turning.*



## **Moutier**

*Our Moutier site—using the latest production technologies and equipment—produces the key components of our world-renowned machines and assembles our high-end automatic turning machines and other multispindle solutions. Key components stamped “made in Switzerland” are produced in Moutier for all of our production sites.*





### **Xi'an**

*Our Xi'an, China site's special testing and development center allows it to fit out machines to customer specifications. In Xian, we produce standard products delivering great value for the money on a global scale.*



### **Taichung**

*In Taichung, Taiwan—a city with a long machine tool-making tradition and broad network of suppliers—Tornos produces mid-range machines. Our Taichung facility's services include customization, setup, designing models, and on-site testing of machines produces. Key components of our machines produced in Taichung are sourced from our Moutier production site.*



We keep you turning



tornos.com

TORNOS SA

Rue Industrielle 111  
CH-2740 Moutier  
Tel. +41 (0)32 494 44 44  
Fax +41 (0)32 494 44 03  
contact@tornos.com

Tornos  
throughout  
the world



**Complies with current CE/EMC safety directives**  
This document is based on information available at the time of publication. While every effort has been made to be accurate, the information contained herein does not purport to cover all details or variations in hardware and software, nor to provide for every possible contingency in connection with installation, operation and maintenance. TORNOS SA assumes no obligation of notice to holders of this document with respect to changes subsequently made. TORNOS SA makes no representation or warranty, expressed, implied, or statutory with respect to, and assumes no responsibility for the accuracy, completeness, sufficiency or usefulness of the information contained herein. No warranties of merchantability nor fitness for purpose shall apply.