



THINK PARTS THINK TORNOS



## MULTISWISS 6x14

Multispindle automatic lathe  
with parallel numerical control.

# THE EFFICIENT AND ECONOMIC SOLUTION FOR MANUFACTURING PARTS OF MODERATE COMPLEXITY

## Automotive



## Medical



## Electronics

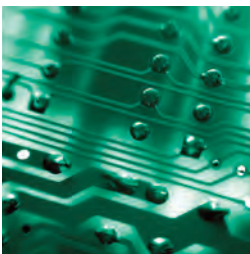

## Watchmaking & Micromechanics



# IN SHORT

**MultiSwiss is a revolutionary new line of products that bridges the gap between single-spindle and multispindle lathes. MultiSwiss is equipped with 6 sliding headstock spindles that use torque motor technology for barrel indexing. Its ultra-high speed makes it possible to achieve near cam driven multispindle cycle times.**



### Productivity

- Completely numerically controlled.
- Ultra-rapid turret indexing.
- Ultra dynamic spindles.
- Independent spindle speeds.



### Performance

- 14 linear axes, 7 C axes.
- Up to 18 tools (3 tools per position).
- Thermo regulated machine core.
- Excellent chip removal and handling.



### Flexibility and ergonomics

- Y axis (optional).
- Chucker (optional).
- Easy to change setup.
- Low tooling costs.
- Reliable production of a wide variety of parts with strict tolerances.
- Open front access.
- Fully integrated peripherals.

### Example of machining on the MultiSwiss 6x14

Material: stainless steel

Production: 7.5 seconds/part

- Polygon milling
- Exterior threading
- Precision +/- 5 microns
- $R_a$  0.15

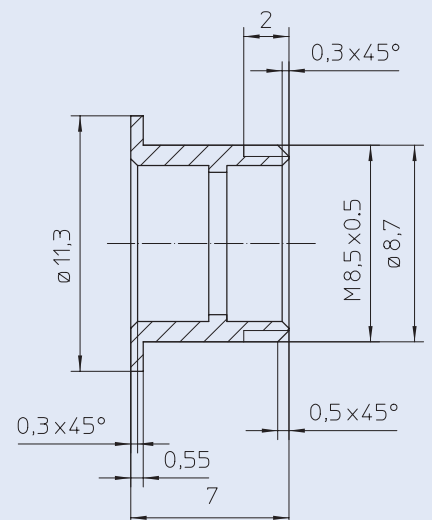
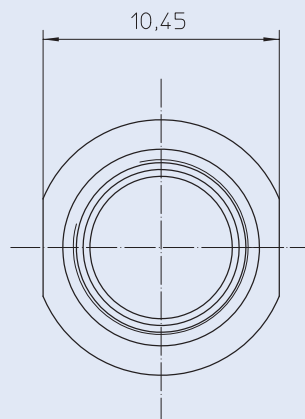

# POWER AND FLEXIBILITY, A GUARANTEE OF FLAWLESS PRODUCTION

3 editions to satisfy all your machining requirements:

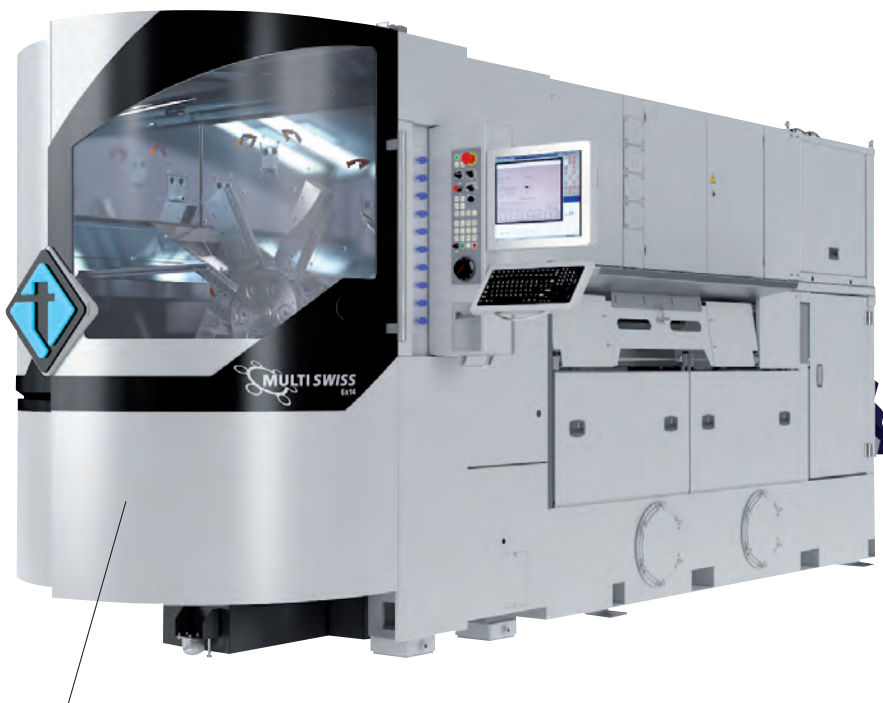

Silver Edition :  
Machine for bar machining only.



White Edition :  
Chucker machine with loading systems  
to suit your needs. Machines can convert  
to bar machines.

## Productive

- Rapid barrel indexing made possible by the torque motor.
- Ultra dynamic synchronous spindle drives.
- Independent speed for each position.

## Precise

- Exceptional rigidity through guide separation.
- Unsurpassed shock absorption with hydrostatic bearings.
- Thermal regulation of the entire machine.

## Outstanding performance

- Sliding headstock spindles with hydrostatic bushings.
- C axis at all positions.
- Polygon milling.
- 14 linear axes, 7 C axes.
- Multi-tool design that allows the fitment of up to 18 tools on the machine.
- Up to 2 tools for second operation work.
- Optimal chip handling.
- Automatic regulation of machine temperature.
- "Plug & Play" system for attachments



Black Edition :  
Equipped with a Y axis  
to broaden the range of parts.

### **Ergonomic**

- Extremely quiet machine operation.
- Front access for easy access to tools during set up.
- Low and high pressure cutting oil supply integrated into slides.
- Presettable toolholders with integrated cutting oil feed.
- Collet adjustment from the front.
- "One piece machine" design, with barfeeder, oil tank and filtration.
- Reduced floor space.

### **Flexible**

- Fast and easy Set up changes.
- Cost-effective manufacturing of parts, even in small batches.
- Use of standard tools.
- Easy to programme with TB-DECO software.
- Optimized cycle time through the selection of barfeeding position.
- Y axis (optional).
- Chucker (optional).



# PRODUCTIVITY AND PERFORMANCE

## **Barrel**

The barrel guarantees maximum precision at all positions. The new indexing technology using a torque motor allows for 0.3 sec indexing times, in complete silence.

This system was tested for its reliability in over 40 million cycles before it received the Tornos validation certificate.

The independent spindles allow for ideal speed at each position and angular control for all milling or radial drilling operations. With the C axis, combined operations (transmit) can also be performed through interpolation of the spindle and slide.

## **Spindles**

The high-power synchronous drive spindles give the machine great power. Acceleration times are extremely short (0-8,000 rpm in less than one second). In addition to its own C axis, each spindle has its own Z axis guided by hydrostatic bearings. This allows for increased shock absorption and better lifespan of the tools and machining surfaces.

The MultiSwiss is extremely silent thanks to its torque motor driving the barrel as well as the spindle drives and thus offers greater comfort of use for the operator.



# GUARANTEED COST-EFFECTIVENESS

## Modular multi-tool design

Up to a maximum of 18 tools can be mounted to the machine, with up to 3 tools per position. It is also possible to mount various types of attachments including: polygon milling attachments, standard or high-frequency drills for main and back work operations, thus expanding the possible configurations of the MultiSwiss.

## Back working

The independent back working slide with capacity for 2 tools, combined with the second operation drive spindle, allow for complex turning or milling operations in masked time that can be oriented with respect to the operations performed.



Frontal stationary drills (ESX-16) mounted on a dual support.



Polygon milling attachment.



1:1 radial drilling attachment.



Stationary barfeeding device at position 1, stationary drill mounted on a dual support.



Radial support for high-frequency spindle.



2:1 radial drilling attachment.



Turning toolholder and additional drilling toolholder.



Basic turning toolholder (16x16).



Frontal drilling attachment.

# PRODUCTIVITY AND FLEXIBILITY...

## **Ergonomics**

The MultiSwiss was designed with the operator in mind. With its excellent frontal access, it is user-friendly, ergonomic and innovative. The machining zone is completely open, allowing for incomparable accessibility. Chip removal is trouble-free thanks to the vertical slides that allow the chips to fall directly into the conveyor unit. The slides are equipped with integrated cutting oil feed, thus limiting the use of pipes that are often difficult to adjust and become traps for chips.

## **Barfeeding: the choice of 1.5 m bars**

This innovative design reduces logistics costs. Loading is easier for the operator, thus allowing for increased machining quality thanks to reduced vibrations. This new barfeeding system also reduces chip length excess thickness for the face milling of each part.





## ... GUARANTEED EASE OF USE

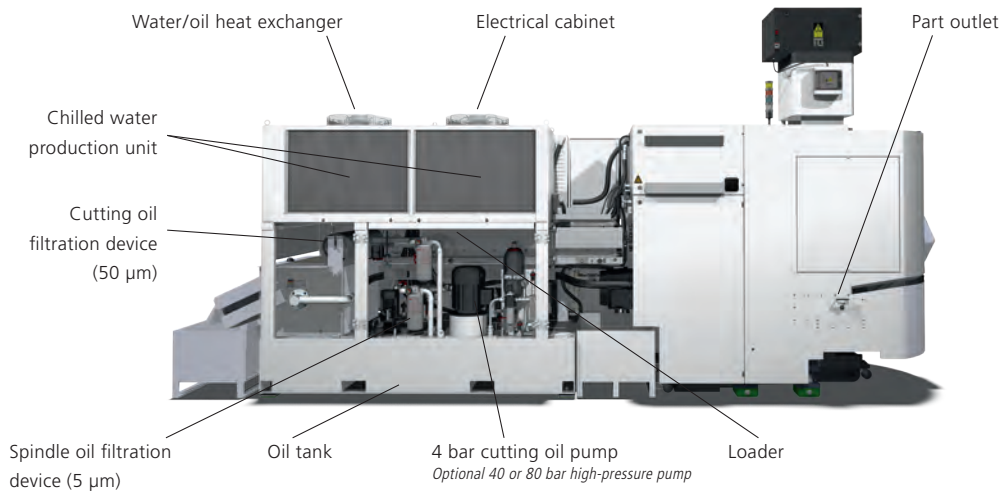

### Compact all-in-one design!

The MultiSwiss takes up less floor space: all peripheral units required for operations are integrated at the back of the machine.

The standard model of the MultiSwiss includes a loader and two-level filtration system.

The container is equipped with an integrated water/oil exchanger, making the machine compatible with centralized water cooling networks. For customers without this type of system, a chilled water production unit can be added to the machine. In addition to the filter, cooling device and barfeeder, the machine's base is designed to include the chip conveyor, and the oil mist extraction device can be easily connected.

This design makes it possible to install a MultiSwiss machine in replacement of single-spindle machines with barfeeders or cam driven machines of similar capacity.

### Programming

The TB-DECO ADV programming software allows for the creation of any multispindle component type:

- Easy programming with icons for productive and unproductive operations.
- Tool library.
- Graphic synchronization of simultaneous operations.
- Calculation of actual machining time (Gantt chart)
- Control of the programme and tool trajectories through graphic simulation.
- Various machining macros for specific operations (thread chasing, drilling-roughing cycles, machining of complex forms, Torx, etc.).
- Free update.
- Tornos Software Hotline.

### Integrated PC

- Program editing on the machine.
- Service instructions available on the machine.
- Remote maintenance.
- Possibility to control various peripheral units.
- Large colour touch screen.
- USB.

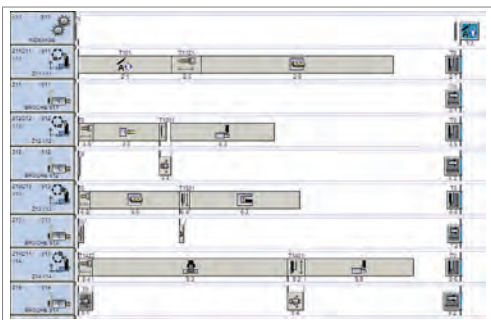

# OPTION

## MultiSwiss Black Edition : Y axis

To make the machine even more flexible, it is possible to add a Y axis on slide no. 3 or 4 of the machine equipment. The Y axis has a stroke of 30 mm and a special plate. It is compatible with all MultiSwiss standard tooling and can be equipped with 3 special tool holders as well as a new device to increase the range of applications.

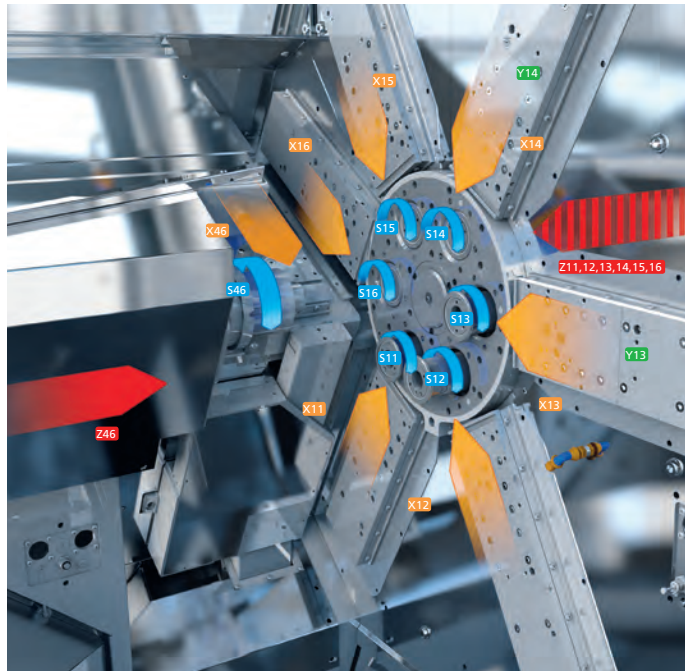

## MultiSwiss White Edition : Chucker

Depending on the parts and quantities to be machined, it is possible to work in « Chucker » mode (machining from billets). By replacing the bar feed system with forged or formed workpiece feed systems, production costs can be drastically reduced. The chucker concept on the MultiSwiss White Edition is very straightforward: the billets are conveyed to position 5 so that the workpiece can be clamped in the collet of the spindle before machining can begin.



# TECHNICAL SPECIFICATIONS

## TECHNICAL SPECIFICATIONS

## MULTISWISS 6X14

Bar passage	mm	4-14	
Max. part length	mm	40	
Max. remnant length	mm	70	
Max. main spindle speed	rpm	8,000	
Main spindle power	kW	5.6	
Main spindle torque	Nm	7.5	
Max. pickoff spindle speed	rpm	8,000	
Pickoff spindle motor power	kW	5	
Pickoff spindle motor torque	Nm	6	
Spindle Z stroke	mm	50	
Pickoff spindle Z stroke	mm	150	
Number of linear axes		14+1 (Y axis Black Edition machine)	
Number of rotating axes		7+1 (option)	
Number of cross slides during operation		5+1 (cutting)	
X stroke of cross slides during operation	mm	40	
Y stroke of the transverse slide in operation (Black Edition machine)	mm	30	
Number of cross slides for back work		1	
X stroke of cross slides for back work	mm	75	
Max. number of tools		18	
Max. number of tools for back work		2	
Spindle cooling		With oil	
Cutting oil filtration	m $\mu$	50	
Oil tank capacity	l	900	
Standard cutting oil pump:	outlet pressure	bars	4
	flow rate	l/min	150
High-pressure pump (options):	a) outlet pressure	bars	35
	flow rate	l/min	40
	b) outlet pressure	bars	80
	flow rate	l/min	26
Weight	kg	7,000	
Installed power	kW	59	
Numerical control		Fanuc	
Programming system		TB-DECO ADV, integrated PC	

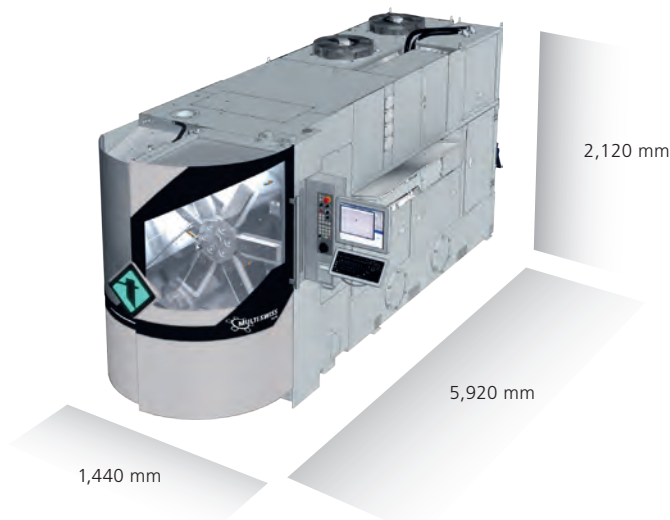

**TORNOS S.A.**

Rue Industrielle 111  
CH- 2740 Moutier  
Tél. +41 (0)32 494 44 44  
Fax +41 (0)32 494 49 03  
contact@tornos.com  
www.tornos.com

**TORNOS TECHNOLOGIES**

**DEUTSCHLAND GmbH**  
Karlsruher Str. 38  
D- 75179 Pforzheim  
Tél. +49 (0)7231 / 910 70  
Fax +49 (0)7231 / 910 750  
contact@tornos.de

**TORNOS TECHNOLOGIES  
FRANCE**

Boîte postale 330  
St-Pierre en Faucigny  
F- 74807 La Roche  
s / Foron Cedex  
Tél. +33 (0)4 50 038 333  
Fax +33 (0)4 50 038 907  
france.contact@tornos.com

**TORNOS TECHNOLOGIES  
IBÉRICA**

Pol. Ind. El Congost  
Avda. St Julià, 206 Nave 8  
E- 08403 Granollers  
Tél. +34 93 846 59 43  
Fax +34 93 849 66 00  
comercial.tti@tornos.com

**TORNOS TECHNOLOGIES  
ITALIA SRL**

Via Cesare Pavese 21  
I- 20090 Opera / MI  
Tél. +39 02 57 68 15 01  
Fax +39 02 57 68 15 230  
italia.contact@tornos.com

**TORNOS TECHNOLOGIES  
US CORPORATION**

840 Parkview Boulevard  
US- Lombard, IL 60148  
Tél. +1 630 812 2040  
Fax +1 630 812 2039  
info-us@tornos.com  
www.tornos.us

**TORNOS TECHNOLOGIES  
UK LTD**

Tornos House  
Whitwick Business Park  
Coalville  
UK - Leicestershire LE67 4JQ  
Tél. +44 (0) 1530 513100  
Fax +44 (0) 1530 814212  
sales@tornos.co.uk

**TORNOS TECHNOLOGIES  
POLAND Sp. z o.o.**

Ul. Spółdzielcza 37-39  
55-080 Kąty Wrocławskie  
Poland  
Tél. +48 71 33 85 618  
Fax +48 71 33 85 617  
poland.contact@tornos.com

**TORNOS TECHNOLOGIES  
(Shanghai) LTD**

Hui Feng Creativity Garden  
Feng Yu Building, 1-2F  
No. 239, Xitai Rd, Xu Hui District  
CN- Shanghai 200232  
Tél. +86 21 6235 1235  
Fax +86 21 6235 1938  
china.contact@tornos.com

**TORNOS BEIJING OFFICE**

Rm.1706, Tower A  
Dongyu Office Building  
Jia #1 Shuguang Xili  
Chaoyang District  
CN- Beijing 100028  
Tél. +86 10 5979 8583  
Fax +86 10 5822 0483  
beijing.contact@tornos.com

**TORNOS TECHNOLOGIES  
ASIA LIMITED**

Rm 1803-06, Corporation Park,  
11 On Lai Street, Shek Mun,  
Shatin, N.T., Hong Kong  
Tél. +852 2691 2633  
Fax +852 2691 2133  
asiapacific.contact@tornos.com

**TORNOS S.A. THAILAND  
REPRESENTATIVE OFFICE**

7th Floor, 19, Bangna -Trad Soi 34,  
Bangna -Trad KM. 3 Road.  
Bangna, Bangkok, 10260  
Thailand  
Tél. +66 2746 8840-1  
Fax +66 2746 8842  
thailand.contact@tornos.com

**TORNOS TECHNOLOGIES ASIA LTD  
MALAYSIA**

**REPRESENTATIVE OFFICE**  
No. 1-1-11, Ground Floor & 1-2-11,  
First Floor, One Terrace Plus,  
Tingkat Mahsuri 4,  
11900 Bayan Lepas,  
PENANG, MALAYSIA  
Tél. +60 4 642 6562 / 4 642 6563  
Fax +60 4 642 6561  
malaysia.contact@tornos.com

**Conforms to the European CE/CEM Safety Standards**

This document is based on information available at the time of publication. While every effort has been made to be accurate, the information contained herein does not purport to cover all details or variations in hardware and software, nor to provide for every possible contingency in connection with installation, operation and maintenance. TORNOS S.A. assumes no obligation of notice to holders of this document with respect to changes subsequently made. TORNOS S.A. makes no representation or warranty, expressed, implied, or statutory with respect to, and assumes no responsibility for the accuracy, completeness, sufficiency or usefulness of the information contained herein. No warranties of merchantability nor fitness for purpose shall apply.